

**SNAP
BY
SNAP**

www.the-snap.de

SNAP is an innovative truss tool that revolutionises the attachment and organisation of cables and power outlets in truss constructions.

Because of its ease of use, SNAP saves time during set-up and dismantling. Cables can be laid significantly faster due to simple handling, which can be accomplished with one hand. SNAP also eliminates the need to remove old adhesive residues from your materials. Use of the reusable SNAP not only reduces your ongoing costs for adhesive tape, cable ties, etc., but also protects your materials by eliminating the rough tearing off of electrical tape attachments.

The clamp is compatible with all trusses and scaffolding having chord tubes measuring 48 mm to 51 mm. Mounting is also possible in otherwise unused brace areas.

SNAP is robust and hard-wearing. It is produced in Germany and is patent protected.

(Pat. Pend. 10 2017 106 520.2)

The goal of HSK-Schulte GmbH was to develop a tool for professionals: Easy to handle, economical to purchase, and durable and flexible in use. With SNAP, we believe we have achieved this goal. Developed and produced in-house, SNAP stands one hundred percent for “Innovations with Plastic - Made in Germany”.

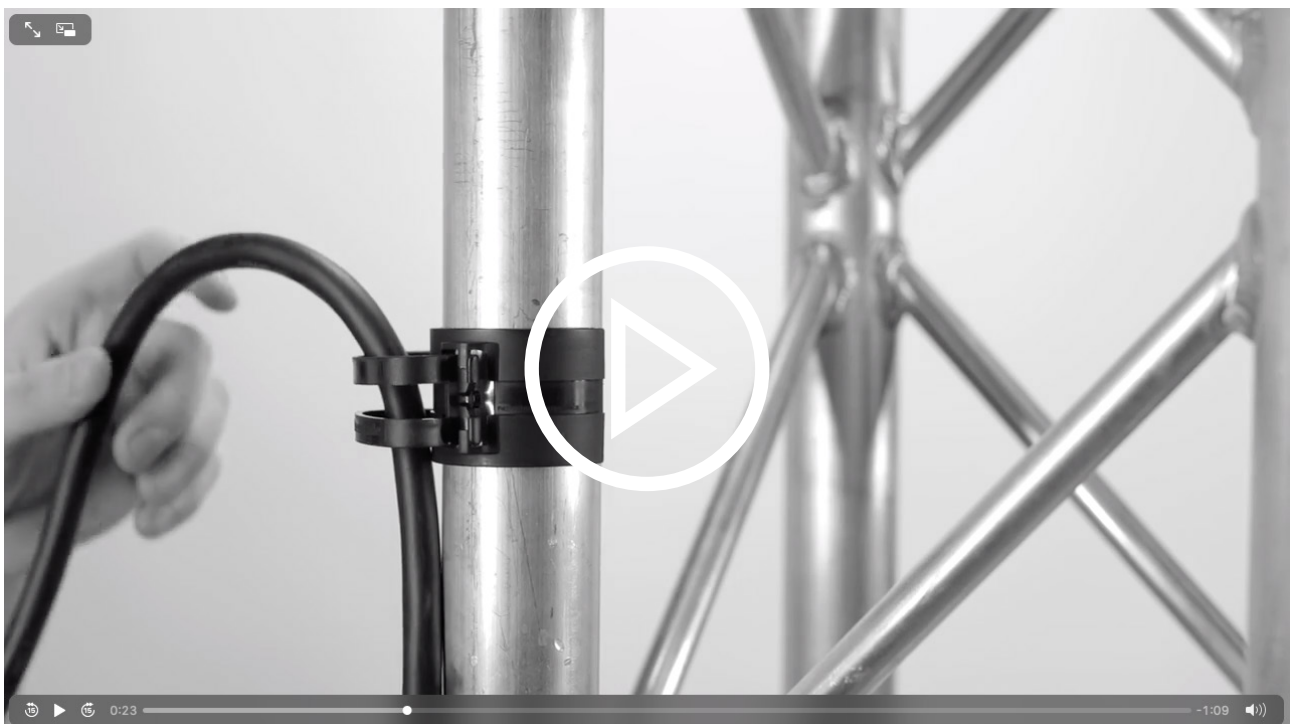



In addition to great attention in various online magazines (Event Elevator, Event Rookie, stage223, etc.), SNAP has also won international product awards, including:

- Rave Award, Infocomm 2017

Category: „Best Lighting Accessory“

- Worship Facilities Expo - WFX 2017 Award

Category: „Category Winner - Best Lighting Product“

- Worship Facilities Expo - WFX 2017 Award

Category: „Lighting Accessory“



THREE IN ONE

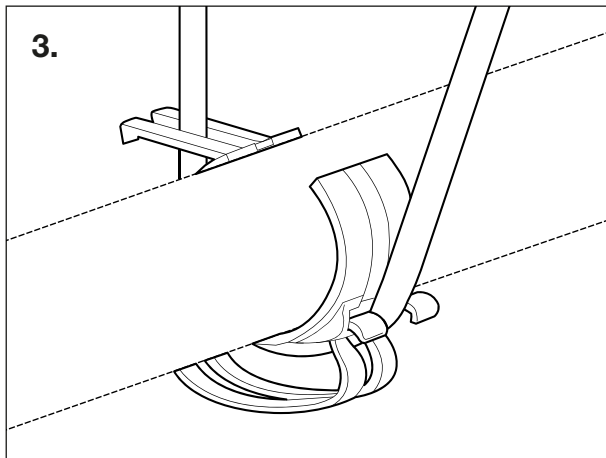
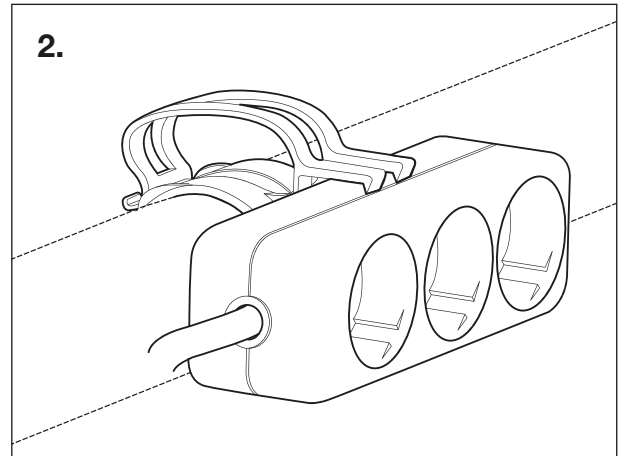
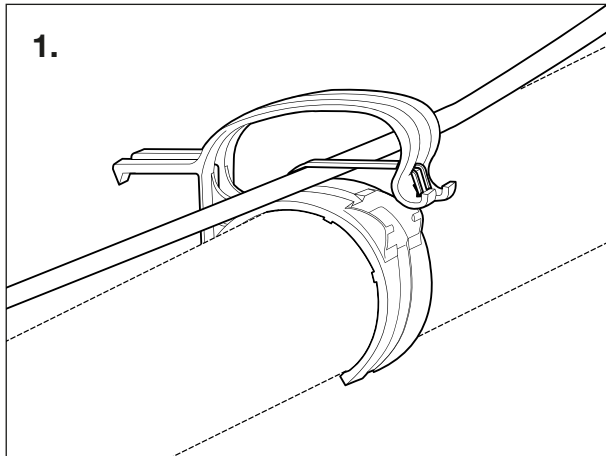

1. Cable routing

- holds cables up to a total cross-section of approximately 950 mm²
- cable clamp with two locking-pins, lockable with one hand
- easy installation and removal of cables (possible with one hand)

Optional attachment of a rubber ring (O-ring)

- holds down individual cables directly on the chord tube
- possible to straighten cables by pulling them taut – axial resistance provided by rubber band
- no change in workflow; continuing easy installation and removal of cables (possible with one hand)

2. Power socket holder

- permits easy clipping of the most popular multiple power socket strips
- no interference with the sockets
- 90° opening of the clamp for the power socket holder, so that plugs can be pulled out with one hand without detaching the clamp from the tube
- possible to use multiple SNAPS for long power socket strips

3. Abrasion protection

- divided clamp to hold suspension elements/wire cables with a diameter of up to 10 mm
- non-slip abrasion protection between truss and suspension element
- no damage to SNAP, due to protected space in the locking area

The Snap.

- saves time during assembly and disassembly
- strong build and reusable
- reduces running cost (tape, zip ties, etc.)
- protects your material (no tearing off of tapes, no sticky remains)

SNAP is available in the colors silver and black, as well with and without power socket holder, called SNAP and SNAP light.

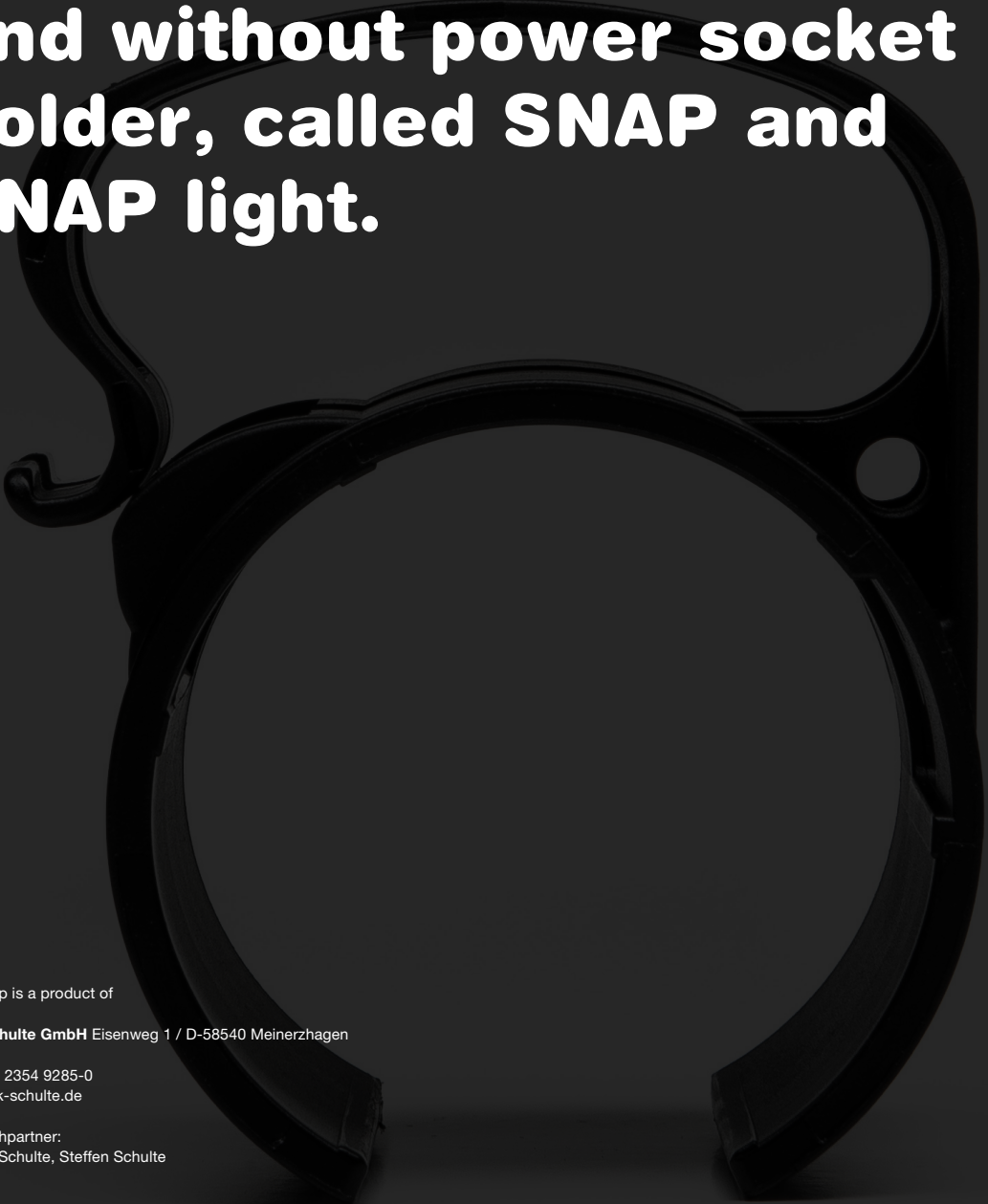

The Snap is a product of

HSK-Schulte GmbH Eisenweg 1 / D-58540 Meinerzhagen

Tel.: +49 2354 9285-0
info@hsk-schulte.de

Ansprechpartner:
Herbert Schulte, Steffen Schulte

www.hsk-schulte.de

Innovations with plastic